

TF

D-Sub connectors - Stamped and Formed Contacts

PRESS FIT STRAIGHT PCB TERMINATION

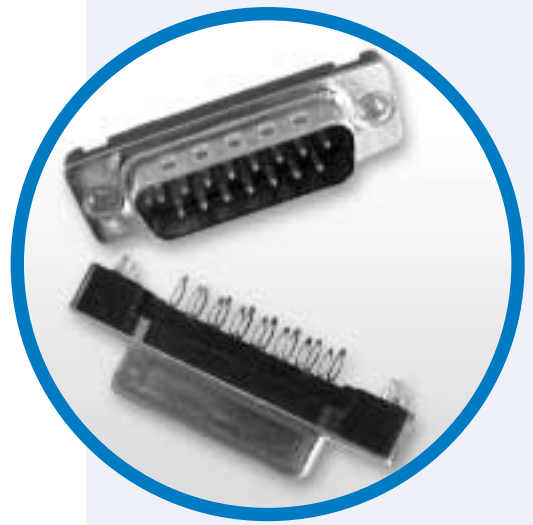

MAIN CHARACTERISTICS

Materials and platings	
Shells	Steel, tin plated
Insulator	Glass-filled thermoplastic, UL 94V-0
Pin contact	Brass, selected gold in mating area ; 2.54µm (100µ inches) min. tin-lead on termination area over ; 1.27µm (50µ inches) min. nickel
Socket contact	Phosphor bronze, selected gold in mating area ; 2.54µm (100µ) min. tin-lead on termination area over ; 1.27µm(50µ) min. nickel
Rear insert	Brass, 2.54µm (100µ inches) min. nickel plated
Boardlock	Brass, 2.54µm (100µ inches) min. nickel plated
Screwlock	Brass, 2.54µm (100µ inches) min. nickel plated (removable)

Electrical Data	
Current rating	5A
Voltage rating	300V AC
Withstanding voltage	1000V AC / rms 60Hz for one minute
Insulation resistance	1000MΩ
Contact resistance	20mΩ max

Climatic Data	
Operating temperature	-55°C to +125°C
Salt spray	24 hours

Mechanical Data	
Single contact insertion force	≤ 3.60 N
Single contact withdrawal force	≥ 0.2 N
Single contact insertion on board	≤ 100 N
Single contact withdrawal from board	≥ 20 N
Standard plating thickness	Gold flash 0.4µm (15µ inches) gold 0.76µm (30µ inches) gold

	Terminal Specification	Boardlock Specification
Finished Hole	1 (+0.09 -0.06)	3.1 +/- 0.05 µm
Cu	> 25 µm	Min 25 µm
Sn	< 15 µm	5-15 µm

DESCRIPTION

The Amphenol "TF" series features eye of needle formed contacts, and insulator with closed entry contacts cavities.

This series gives you Amphenol's high standards of quality and reliability to meet all your technical requirements.

*Solderless
straight PCB
mount
connectors*

APPLICATIONS

- Industrial
- Telecom
- Any backplanes connections

TF / E4



Amphenol

Socket version

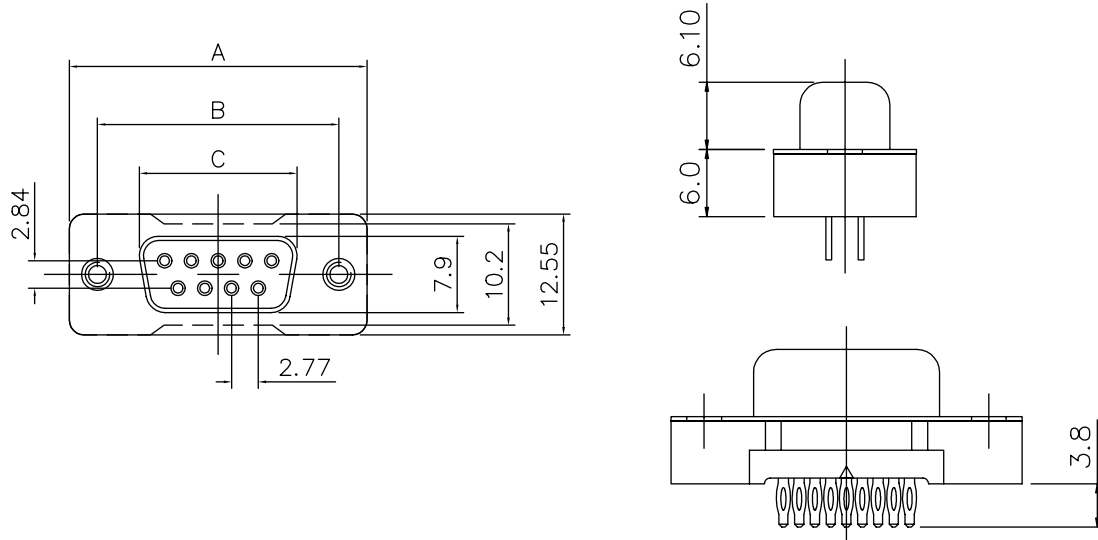

Plug version

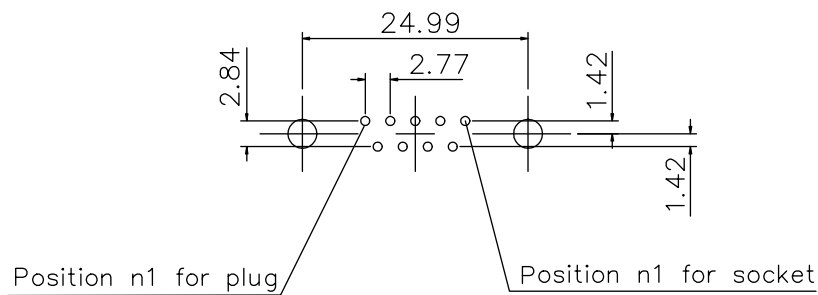
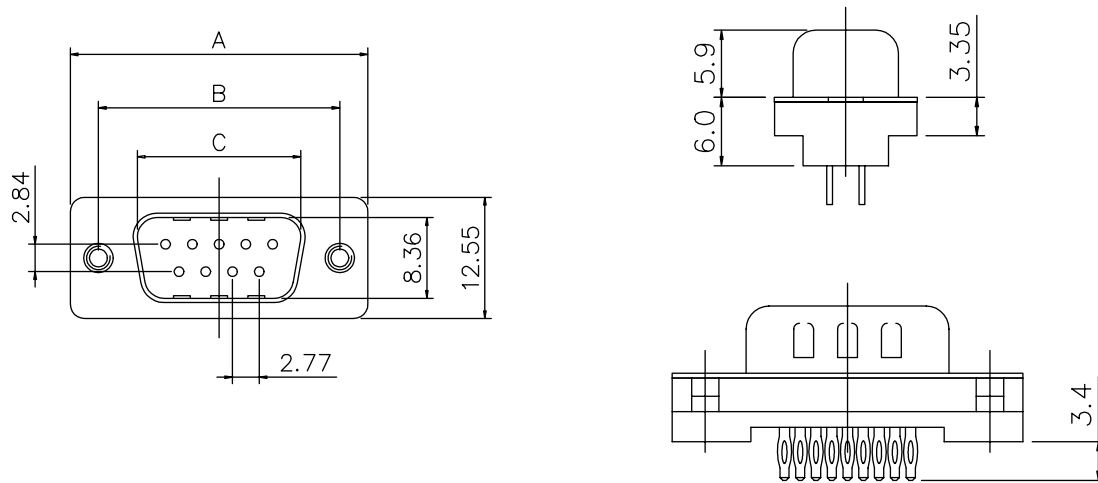

For PCB holes diameters, see on page 1 (finished holes)

Nb OF CONTACTS	DIMENSIONS mm (inch)			
	A	B	C socket	C plug
9	30.81 (1.185)	24.99 (0.984)	16.92 (0.666)	16.33 (0.643)
15	39.14 (1.54)	33.32 (1.312)	25.50 (1.004)	24.66 (0.97)
25	53.04 (2.088)	47.04 (1.852)	38.96 (1.534)	38.38 (1.511)
37	69.32 (2.729)	63.50 (2.5)	55.42 (2.182)	54.84 (2.16)

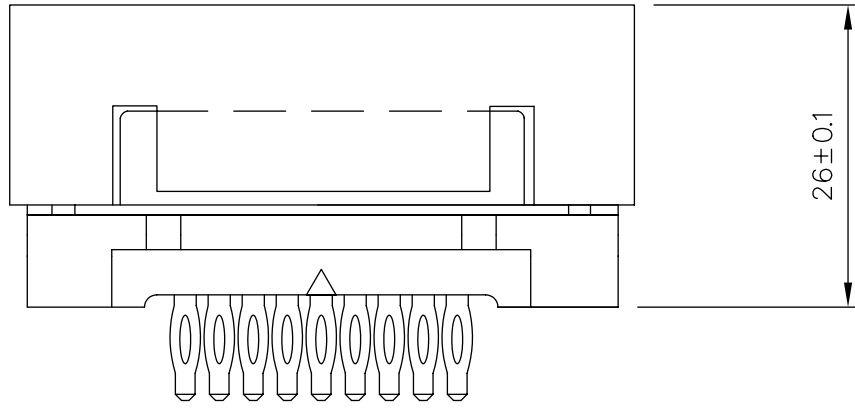

Female

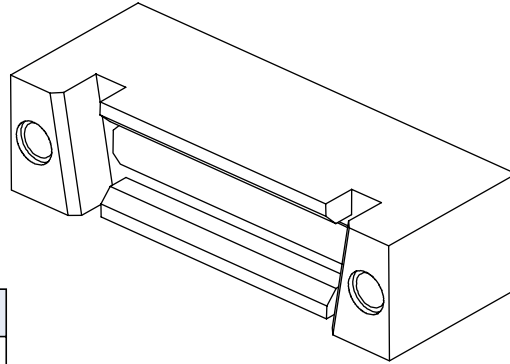

Size of connectors	Tooling PN
9	981 MC
15	982 MC
25	983 MC
37	984 MC

Male

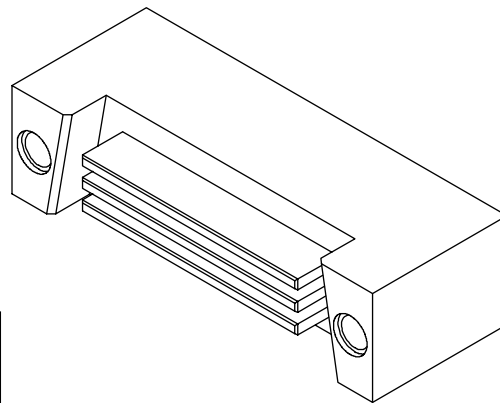

Size of connectors	Tooling PN
9	985 MC
15	986 MC
25	987 MC
37	988 MC



Board mounting option

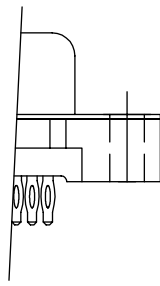

Option 0

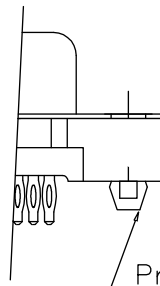

Option 1

Press Fit Boardlock

Flange mounting option

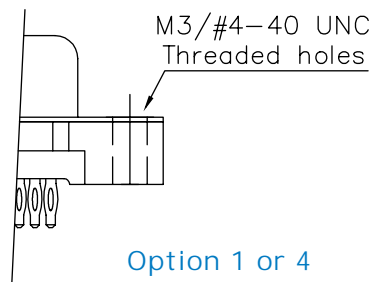

Option 1 or 4

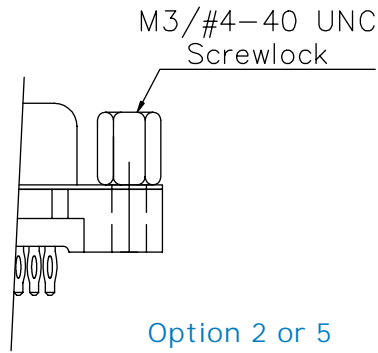

Option 2 or 5

How to order

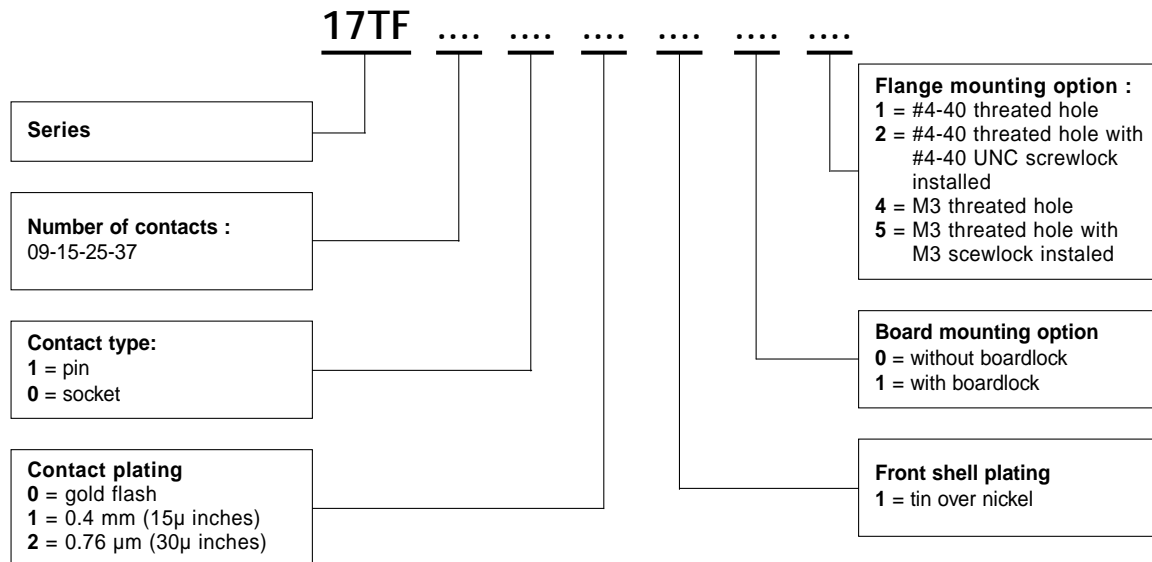

Do not hesitate to contact us for further information



Amphenol

Amphenol Socapex
 Telecom Business Unit
 21, chemin du Défois - BP 349
 F - 39100 Dole
 Fax: +33 (0) 3 84 82 94 11
<http://www.dsubconnector.com>
Technical support
 Tel.: +33 (0) 3 84 82 94 00